

425 SERIES

PTO Connect Torque & Power Monitoring System

PRODUCT OVERVIEW

PRECISION. DATA. INNOVATION.



C.R. MECHTECH CO., LTD.

Tel/Line: 081-988-4482
www.crmechtech.com

425 SERIES

Integrated with



PTO Connect Torque & Power Monitoring System

What is it designed to do?

Datum Electronics PTO (Power Take Off) Connect Shaft Torque and Power Monitoring System will monitor and log the torque, shaft speed and transmitted power accurately when testing new systems driven from all standard PTO Shafts.

The tractor's PTO or stub shaft transfers power from the tractor to the PTO-driven machine or implement. Power transfer is accomplished by connecting a drive shaft from the machinery to the tractor's PTO stub shaft. Common examples include elevators, grain augers and silage blowers. The PTO and drive shaft rotates at 540 rpm (9 times/sec.) or 1,000 rpm (16.6 times/sec.) when operating at full recommended speed. At all speeds, they rotate in proportion to the speed of the tractor engine.

Measurement and Monitoring

Efficient measurement and monitoring of this power can be a useful tool in research and analysis into the performance of a tractor transmission. It highlights efficiency savings measurement and control.

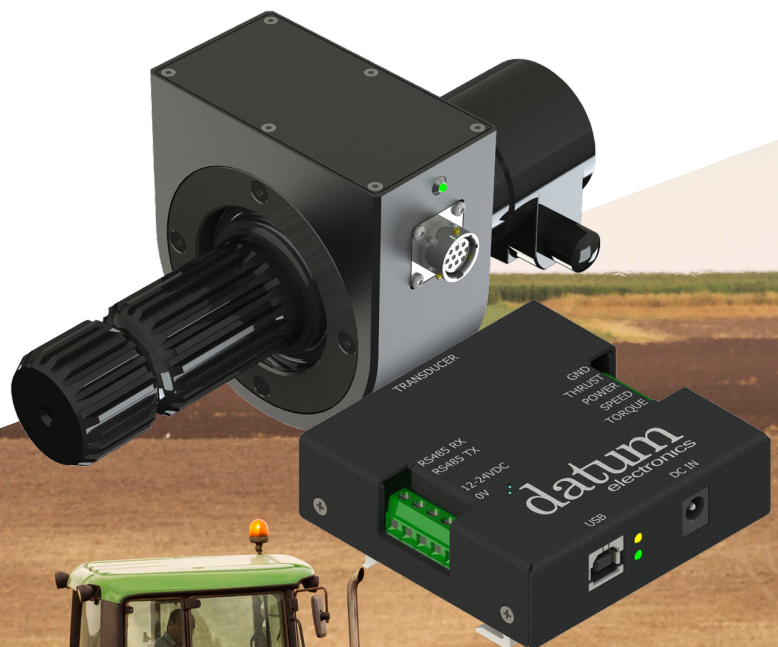

System Advantages

PTO Connect System Performance and Benefits

Power Monitoring

Robust Design for use in field applications

IP65

Easy Installation

Accurate Results (0.1% Accuracy)

Digital outputs of Data through RS485 and Wi-Fi with Datum Connect App, including USB PC test software

Analogue Outputs Available

System Outline

Non-contact transmission

The PTO Connect is a contactless rotary torque transducer. The transducer measures torque strain in the shaft via an on-shaft microprocessor circuit, which also measures shaft rotational speed.

The torque and speed data is transmitted to the stationary part via a contactless method and is transmitted to the DCI (Datum Connect Interface). The DCI has a USB data connection which can be connected to a Laptop or PC running Datum Connect software which allows the display and logging of Torque, Speed and Power data.

The PTO Connect System has a non-contact transmissions system that provides a digital output directly proportional to Torque. Supplied as a complete transducer with bearing to support the stator unit, this robust design gives performance data by actual measurement on the rotating drive shaft. It is suitable for most power take off applications.

The PTO system has a female coupling on one end and a male fitting on the opposite end. The female end is coupled to the male end of the application. The PTO system acts like an extension adaptor, with the male end replicating the male end of the application. The torque and speed signals are transmitted from the shaft to a static cover assembly.

Clockwise/Anti-Clockwise Measurement

Measuring torque in both directions, clockwise and anti-clockwise the system provides accurate readings of Power, Torque and Speed logged to DCI.

System Items Supplied

Included as standard with the PTO Transducer:

Description	Quantity
PTO Transducer	1
PTO Connect Cable	1
DCI	1
USB cable	1
Power Supply - 110-230Vac	1
Calibration Certificate	1

System Connections

Familiarisation

Simple Diagnostics, Testing and Connection

Before installing your PTO Transducer into the rig or vehicle we would advise you to familiarise yourself with its connections and operation by performing a bench test.

By connecting the Transducer directly to a DCI (example A below), or to a PC via the DCI (example B opposite), you will be able to rotate the shaft to generate an output signal of RPM. By applying a small torque by hand to the shaft you will also be able to see the change in the torque signal output via DCI or app.

Once you are familiar with the PTO transducer and its outputs, continue to install as normal. If any questions arise at this stage please call our product support team for advice.

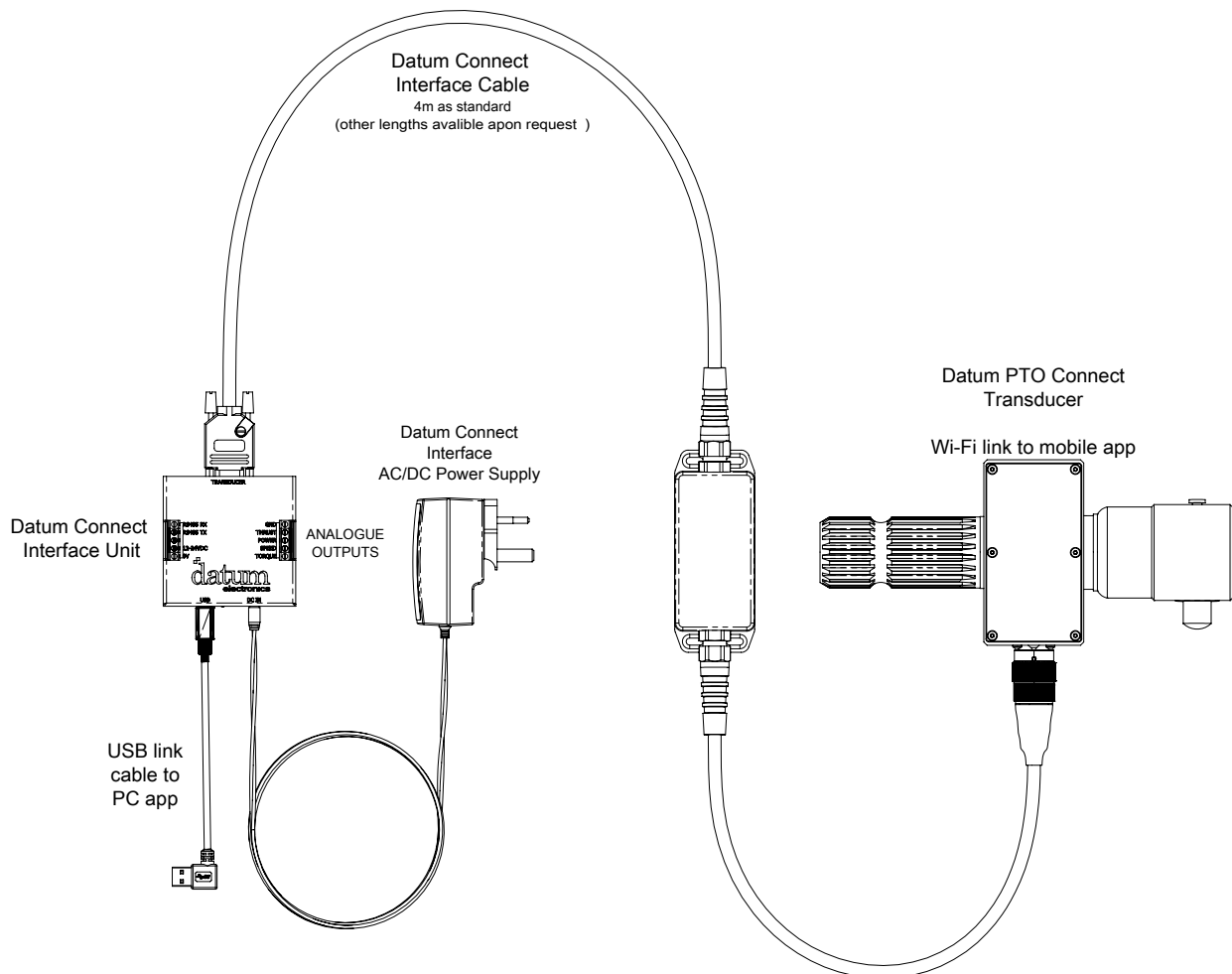

Mechanical Installation

Anti-rotation Point

The body of the PTO transducer is suspended on bearing on the rotating shaft. An anti-rotation tether point is provided on the transducer to prevent the transducer body from rotating with the shaft. A chain, cable tie or similar are examples of acceptable tethers. Under no circumstances should the interface cable be relied upon as an anti-rotation tether.

The bearing in the transducer is intended for supporting the body of the transducer only and should not be used to support the shaft or assembly to which the transducer is mounted.

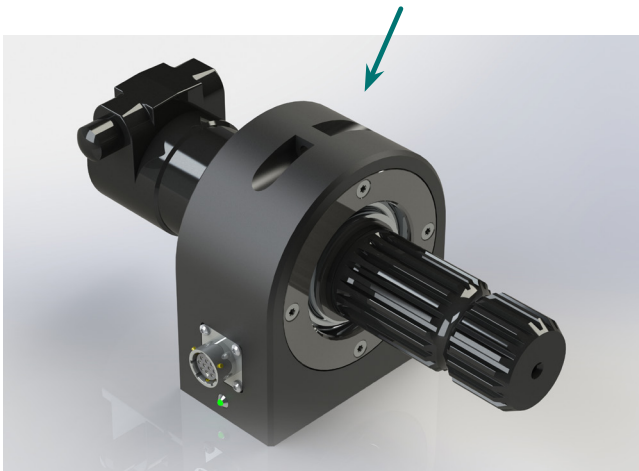

Installation

The Transducer should be attached to the PTO shaft output of the vehicle and a suitable tether arranged to a stationary part of the vehicle to prevent the outer body from rotating when the PTO shaft rotates. The interface cable must NOT be used for this purpose. The connecting cable should be connected between the Transducer and DCI, which should be mounted in a convenient

location, away from rotating parts and protected from dirt and moisture.

The RS485 output is connected to the DCI (supplied). Torque, Speed and Power, can be monitored from a connected device. Analogue outputs are available to be locally monitored via the DCI.

Safety - Ensure The PTO Shaft is Guarded

A tractor power take-off (PTO) and the power take-off drive shaft of a machine are very dangerous if used and not correctly guarded. Every year people are killed or seriously injured in accidents involving PTOs and PTO drive shafts. Most of these accidents are preventable if the PTO and PTO drive shaft are fitted with guards of good design which are properly used and maintained.

Note: Broken, damaged or badly fitting guards can be just as dangerous as no guard at all.

Protect the tractor PTO with a shield covering the top and both sides of the PTO so that it stops anyone making contact with it, either with parts of their body or their clothes. Make sure this shield is well constructed and capable of supporting a downward load of at least 120 kg. When the PTO is not in use, it may be covered by a fixed cap. Guard PTO drive shafts by enclosing them along their full length, from the tractor to the first bearing on the machine.

Take care to route all the PTO Transducer cables safely away from the rotating PTO shaft and any

moving mechanical components. Secure them with cable ties to ensure there is no possibility of fouling on the rotating shaft.

Further advice on guarding the PTO shaft is available from in the form of a PDF document on the Health and Safety Executive website at the following link:

www.hse.gov.uk/pubns/ais40.pdf

Calibration

The Transducer is supplied with a calibration certificate for reference purposes. The output from the transducer is described in mV/V and

related to the data transmitted via the RS485 output from the transducer.

The DCI is supplied pre-set to the transducer's calibration values and should not need to be adjusted other than a possible re-setting of the Transducer Zero Point through the app..

Operation

The Datum Connect App will show the Torque, Speed and Power measured by the transducer.

The Datum Connect app also provides data logging capabilities along with the ability to configure DCI analogue outputs

Output Data

Read More from Your Data

Datum Connect will provide you with accurate torque data. The following graphs show examples of some data output possibilities of the PTO Connect's Transducer.



Specifications

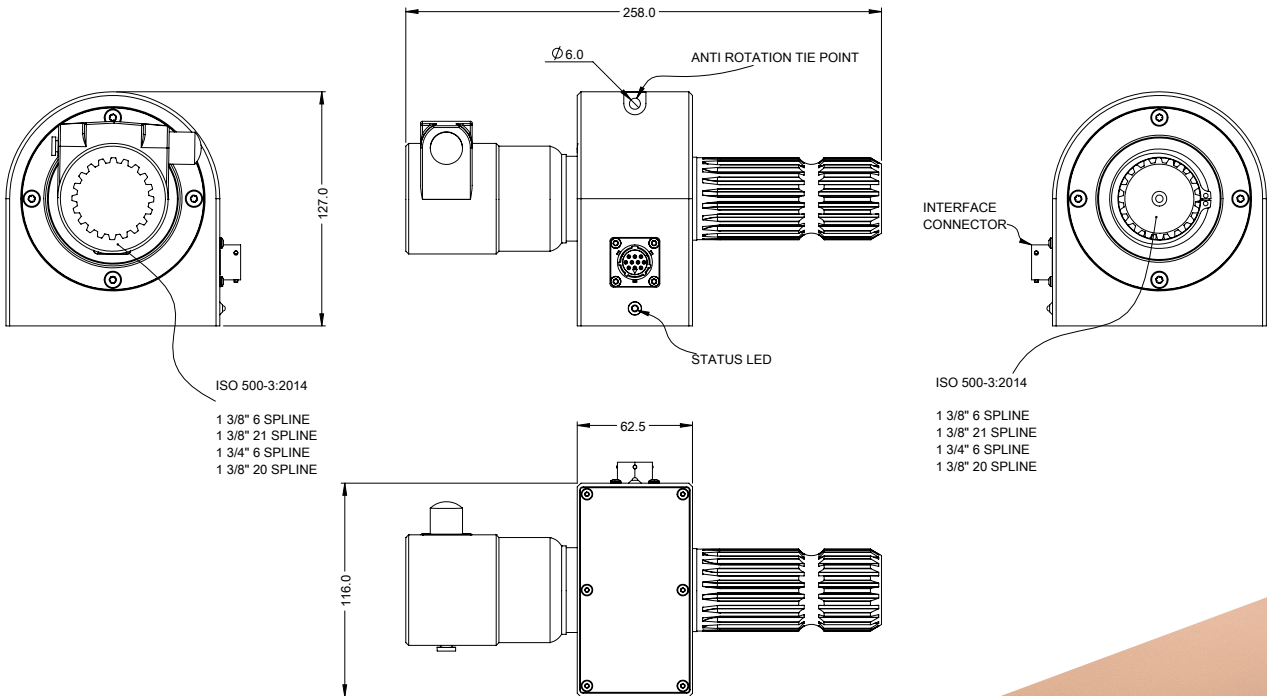

Mechanical Interface Specifications

425 Series PTO Transducer compatible spline configurations.

Splined Power Take Off Shaft Profiles:

- A** Male / Female 1" ³/₄ x 6 spline
- B** Male / Female 1" ³/₄ x 20 spline
- C** Male / Female 1" ³/₈ x 21 spline
- D** Male / Female 1" ³/₈ x 6 spline

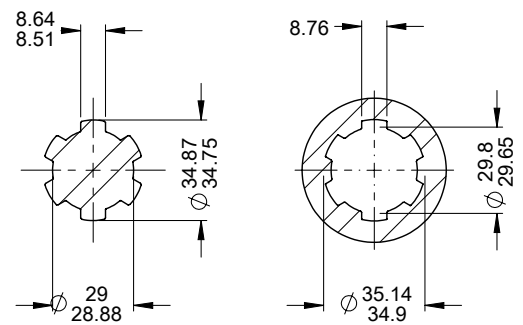
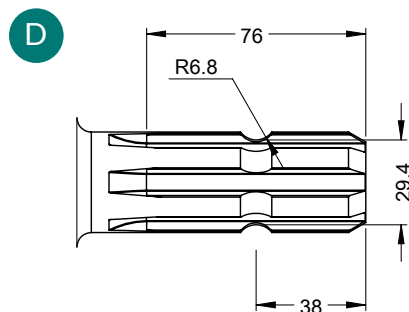
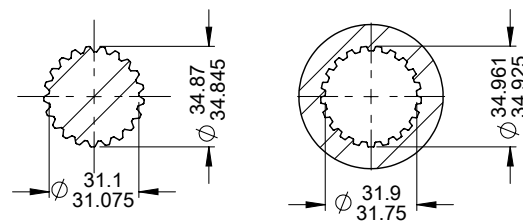
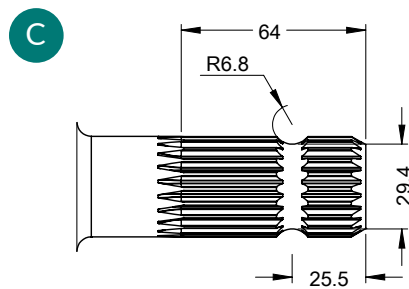
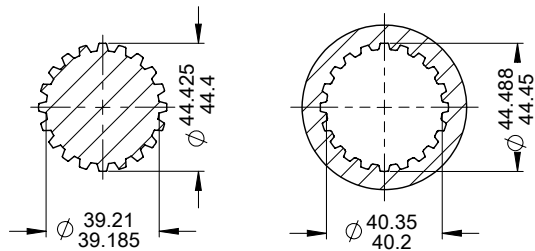
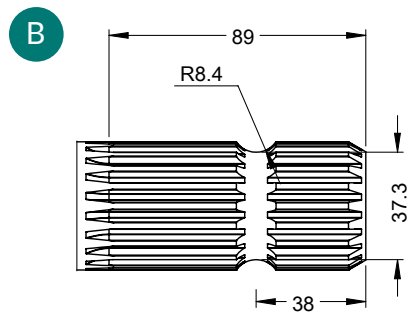
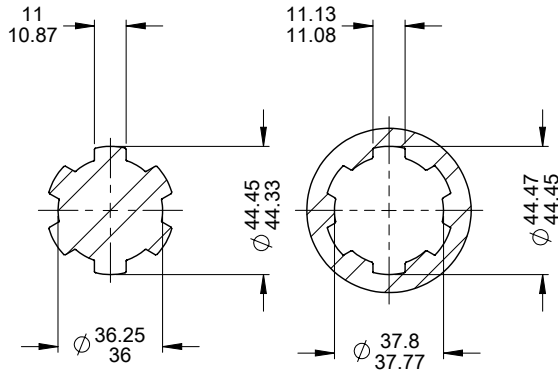
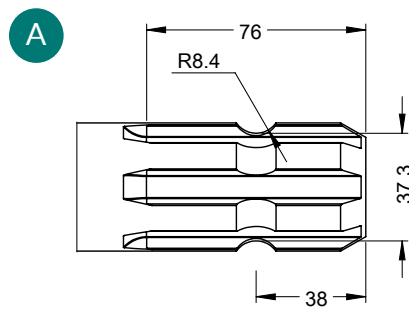

3D models and STEP files are available from Datum Electronics to assist project planning. Please contact Datum Electronics for more information.

Pre-Calibrated and Tested

Test Certificate

The PTO Shaft Torque and Power Monitoring System is calibrated on test rigs traceable to UK National Standards.

The PTO Transducers will be subjected to a series of test cycles starting with a proof load cycle(s) and then followed by a series of calibration cycles.

Loads are applied from zero torque to the maximum working torque of the Transducer.

The data shown on the test certificate:

- The test equipment used
- Calibration date
- A table of the actual loads applied against the output
- The output is described in either:
 - mV/V - this is the raw strain signal from the torque shaft
 - Nm/Lbft - this is the calibrated output of the transducer
- PTO Transducers have an output that is processed and displayed in the instrumentation or user software.
- RPM

PTO Model	Torque (Nm)	Power	Speed (RPM)	Accuracy	Protection	System weight (kgs)
Male / Female 1" 3/4 x 6 spline	2500	190HP or 141kW at 540rpm 350HP or 261kW at 1000rpm	540/1000	0.01%	IP65	5.4
Male / Female 1" 3/4 x 20 spline	2500	190HP or 141kW at 540rpm 350HP or 261kW at 1000rpm	540/1000	0.01%	IP65	5.4
Male / Female 1" 3/8 x 6 spline	1800	135HP or 101kW at 540rpm 253HP or 188kW at 1000rpm	540/1000	0.01%	IP65	4.4
Male / Female 1" 3/8 x 21 spline	1800	135HP or 101kW at 540rpm 253HP or 188kW at 1000rpm	540/1000	0.01%	IP65	4.4

For alternative spline arrangements e.g. Male/Male, we offer a bespoke design service - please speak to sales.

For higher RPM requirements - speak to sales.

Digital output capable via 12v power supply - Not supplied. (Analogue outputs not available via 12v). Quality battery needed for consistent power supply.

Maintenance

Serviceable Items: Bearings

The bearings are the only component on the PTO Power Monitoring System that may require servicing depending on operating conditions. The following provides information on the bearing life under load conditions.

The body of the Transducer is supported by a bearing. The life of the bearings at normal running RPM of half the rated RPM is 10 years continuous use.

If you have requirements for high duty sensors

where bearing life may be a concern due to other external loads, ask our support team for additional information on our bearing less RS425 and FF425 ranges. These RS/FF designs provide a high degree of flexibility with regard to mounting tolerances and maintenance free operation.

If the shaft of the Transducer is bent the balance of the Transducer will be disturbed and the bearing life will be greatly reduced. Excessive load or mounting misalignment will also effect the life of the bearings. Bearings can be serviced by a return to Datum Electronics.

Glossary of Terms

Engineering Units

The transducers/sensors are calibrated in engineering units of either Nm or Lbft.

Full Scale Output

The mV/V is the output from the transducer when the rated load is applied.

mV/V

To measure torque we use a bridge network of resistive strain gauges. These change resistance with the applied strain. The output they give is a ratio of the voltage applied and the mV change in signal from the bridge.

This mV/V ratio is normally quoted in the form $1.55\text{mV/V} = 1000\text{Nm}$. The mV/V value is established at calibration by applying a known torque to the shaft. This ratio will remain constant

for the life of the transducer/sensor unless damaged.

Noise

Irregular fluctuations that accompany a transmitted electrical signal but are not part of the data generated from the sensor.

Proof Load

The proof load is the load to which the transducer/sensor has been tested - occasional loading to this level should not damage the transducer. Repeated loading to this level will reduce the fatigue life of the transducer and may cause small zero offset over time (usually measured in either Nm or lbft).

Rated Load

The Rated Load is the designed full load of the transducer/sensor (measured in either Nm or lbft).

Raw Data

Raw data is the raw strain level from the torque shaft. It will include any zero offset.

The scaling of the raw data will require:

$\text{Torque [Nm]} = (\text{raw data [mV/V]} - \text{zero offset [mV/V]}) \times (\text{rated torque [Nm]} \div (\text{full scale output [mV/V]}))$.

Sensor

A sensor measures a physical quantity and converts this into a signal. The physical quantity is torque or torsional strain, this is converted into serial data.

Note: The words transducer and sensor are often used in this context to mean the same thing.

Span

This is the value of output at the rated load.

Either given in terms of mV/V signal or Nm or lbft when in engineering units.

STEP files

A STEP file is a widely adopted CAD file format used to share 3D models between users with different CAD systems.

Torque

The twisting force on the shaft created by the driving force (motor) and the resisting force (brake or gear).

Transducer

A transducer is defined as a device that converts one form of energy to another. In terms of the PTO Power Monitoring System the transducer converts torque into serial data.

Note: The words transducer and sensor are often used in this context to mean the same thing.

Zero

This is the value of the signal when the shaft is completely unloaded. Normally quoted in mV/V.

สอบถามเพิ่มเติมติดต่อ



C.R. MECHTECH CO., LTD.

@crmechtech



Tel/Line: 081-988-4482

Email: sales@crmechtech.com

www.crmechtech.com

90/153 หมู่ 15 ถ.บางนาตราด กม.5 ต.บางแก้ว
อ.บางพลี จ.สมุทรปราการ 10540